

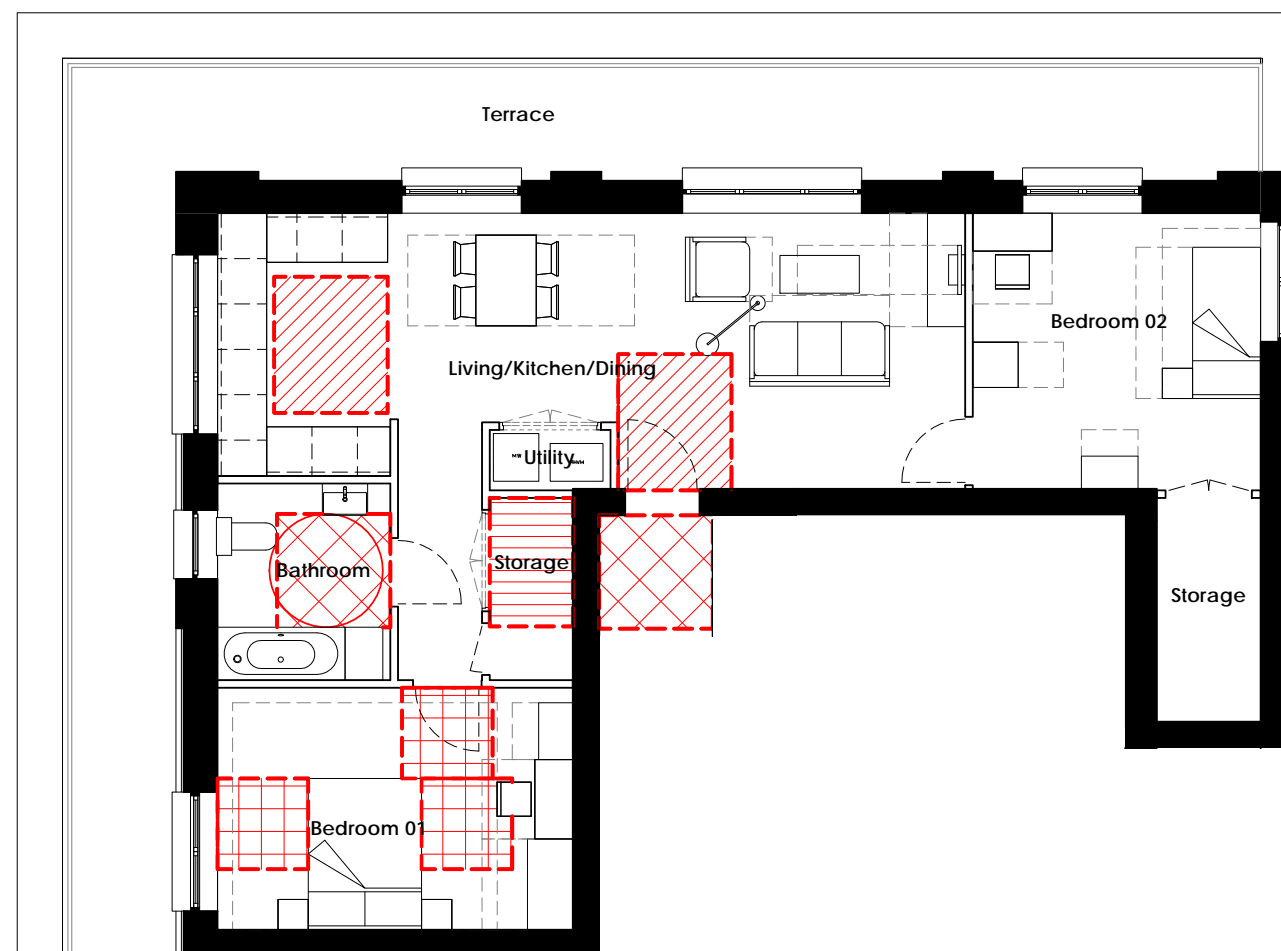

Do not scale from this drawing. Verify all dimensions on site. Drawing should be read in conjunction with information from all other design consultants and contractors. All drawings in digital format are for reference only, paper copies are available on request.

RMA SUBMISSION

© Maccreanor Lavington Ltd.

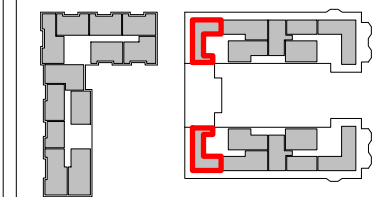
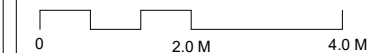

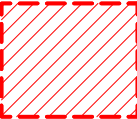
Private Sale 2B3P Wheelchair Adaptable Flat

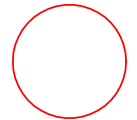
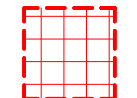
-  1800 x 1500 Manoeuvring Zone
-  1700 x 1100 Wheelchair Storage
-  1500 x 1500 Manoeuvring Zone
-  1500 Turning Circle
-  1200 x 1200 Manoeuvring Zone

**NOT FOR APPROVAL
ILLUSTRATIVE ONLY**

Rev	Details	Drwn	Chkd	Date
-	RMA Submission	OJ	GW	25/10/17

MaccreanorLavington

77 Bastwick Street,
London, EC1V 3PZ

t +44 (0)20 7336 7353
e uk@ml-architects.com

Client
Brent Cross South Limited Partnership

Project
549 Brent Cross - Plot 12

Title:
Typical Wheelchair Unit Plan
Type PS-F-2B-3P-1S-WAD-G

Scale:
1:100 @ A3

MLUK-549-A-L-XX-5111