

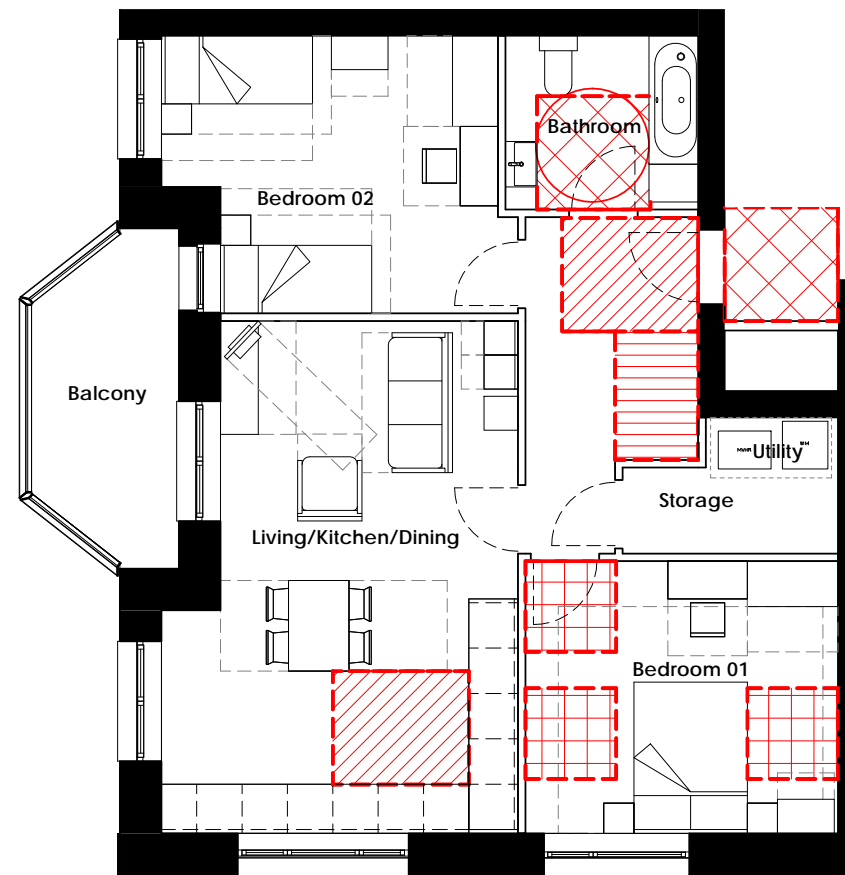

Do not scale from this drawing. Verify all dimensions on site. Drawing should be read in conjunction with information from all other design consultants and contractors. All drawings in digital format are for reference only, paper copies are available on request.

**RMA SUBMISSION**

© Maccreanor Lavington Ltd.

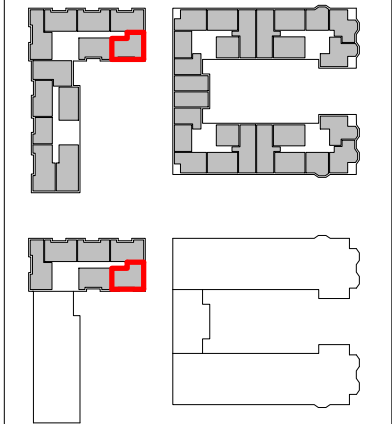
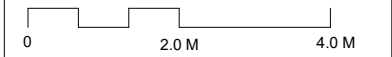
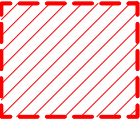

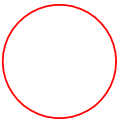
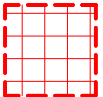
-  1800 x 1500 Manoeuvring Zone
-  1700 x 1100 Wheelchair Storage
-  1500 x 1500 Manoeuvring Zone
-  1500 Turning Circle
-  1200 x 1200 Manoeuvring Zone

**NOT FOR APPROVAL  
ILLUSTRATIVE ONLY**

**Affordable Rent 2B4P Wheelchair Accessible/Adaptable Flat**

- RMA Submission	OJ	GW	25/10/17
Rev Details	Drwn	Chkd	Date

**MaccreanorLavington**  
77 Bastwick Street,  
London, EC1V 3PZ  
t +44 (0)20 7336 7353  
e uk@ml-architects.com

Client  
Brent Cross South Limited Partnership  
Project  
549 Brent Cross - Plot 12

Title:  
Typical Wheelchair Unit Plan  
Type AR-F-2B-4P-1S-WAD-F  
Scale:  
As indicated @ A3

MLUK-549-A-L-XX-5107